

Instruction Manual of DJS5169 Electronic DC Energy Meter



Technology consultation: 0816-2280829

Quality compliant: 0816-2278273

Sales tel: 0816-2278150/1/2/3/4

Sales fax: 0816-2281934

Executive standard: GB/T29318-2012

Address: No.98 Youxian East, Youxian District, Mianyang, Sichuan,
China

Code no.: 621000

E-mail:wbwm@wbdz.cn

<http://www.wbdz.cn>



Mianyang Weibo Electronic Co., Ltd.

Preface

Thank you for choosing DJS5169 Electronic DC Energy Meter. We hope that this product will bring you a pleasant application experience.

If the package or product appearance is damaged when you receive the product, please contact us or your supplier immediately.

In order to make this product work better and avoid future troubles caused by improper operation, please read this instruction manual carefully before installing, using or maintaining the product.

Please keep this manual carefully for your future usage.

Please read the safety instructions in the first section of this manual before installing this product.

Please note that the content is subject to change without notice.

Catalogue

1.Safety usage instructions	1#
2. Product introduction.....	2#
2.1 Summary	2#
2.2 Product features.....	2#
3 Structural features and operating principle	3#
4 Key technical parameters.....	3#
4.1 Key technical parameters.....	3#
4.2 Pulse output.....	4#
5 Outline dimension	4#
6 Installation and usage.....	4#
6.1 Installation method.....	4#
6.2 Installation precautions.....	4#
6.3 Wiring	5#
6.3.1 Terminals definition	5#
6.3.2 Power supply wiring	6#
6.3.3 Communication wiring.....	6#
6.3.4 Input wiring.....	7#
6.3.5 Energy pulse output wiring.....	7#
6.4 Usage	8#
6.4.1 Panel description.....	8#
6.4.2 Button description	9#
6.4.3 Battery display	9#
6.4.4 Exception display	10#
6.4.5 Display configuration	10#
7. Communication protocol.....	11#
7.1 MODBUS-RTU protocol.....	12#
7.1.1Summary	12#
7.1.2 Function code description	14#
7.1.3 Abnormal response	15#
7.1.4 Example of communication messages	15#
7.1.5 Parameter register table.....	17#
7.2 DL/T645-2007 protocol.....	30#
7.2.1Summary	30#
7.2.2 Frame format	30#
7.2.3 Data identification	32#
7.2.4Communication packet description.....	38#
8 Note.....	44#
9 After sales service	44#



9.1 New product quality assurance.....	44#
9.2 Product warranty limit.....	44#
10 Package, transportation and storage.....	45#
10.1 Storage	45#
10.2 Transportation and storage.....	45#
Complimentary clause	45#

1.Safety usage instructions

This instruction manual is used to describe DJS5169 DC Energy Meter. Please read this instruction manual carefully before installing, operating and maintaining this product. You are supposed to have basic knowledge in electrical engineering area by this instruction manual.

The input terminals of this product may carry dangerous voltage during installation and usage, so the input signal and power must be cut off before any internal or external operation of this product.

The following special information may appear on this manual or on the product to alert you to potential hazards or to remind you of safe operation. Any installation and maintenance work must be performed by a professional.



Danger

Indicating potential dangerous situations which may cause death or serious injury if it is not obeyed.



Warning

Indicating potential dangerous situations which may cause damage to the equipment if it is not obeyed.



Attention

Providing other helpful information which is not mentioned in Danger and Warning.



Attention

- The product is an integrated structure, and the internal components are matched and calibrated;
- Do not damage or modify the label or logo of the product, do not disassemble or modify the product;
- This product cannot be recycled when it is discarded. Please contact a qualified recycling department for disposal.



Warning

This instruction is not intended for use as an operational reference by untrained personnel. The company will try its best to solve the problems caused by the outside of its normal use, but does not assume the relevant safety responsibility.



2. Product introduction

2.1 Summary

DJS5169 Electronic DC Energy Meter is a new generation of programmable intelligent instrument. The instrument supports DC signal monitoring of two channels voltage and two channels current. It can be widely applied to DC signal equipment such as DC charging pile and DC power supply. Equipped with one channel RS485 communication interface, this instrument supports MODBUS-RTU and DL/T645-2007 communication protocol.

DJS5169 Electronic DC Energy Meter complies with the following standards:

GB/T 29318—2012 “Electric vehicle non-vehicle charger energy metering”;

JJG 842-1993 "DC electronic energy meter";

DL/T 645—2007 “Multi-function energy meter communication protocol”;

MODBUS-RTU communication protocol.

2.2 Product features

As an advanced intelligent and digital power grid front-end acquisition component, the DC Energy Meter mainly monitors the voltage, current, power, and electronic energy in the electrical circuit in real time. The instrument cluster circuit measures, displays, and communicates in one product. The advantages of this instrument are high measuring accuracy, wide measuring range, good stability, long-term work for free adjustment, programmable parameter setting, etc. It is cost-effective and the function combination is simple and practical.

- Full parameter measurement and multiple energy accumulation;
- The input signals between the roads achieve electrical safety isolation;
- Strict EMC and safety protection design and higher reliability;
- High input impedance voltage sampling scheme ($\geq 2\text{M}\Omega$), which has little effect on the measured line;
- Fast response ($< 100\text{ms}$) and real-time monitoring of grid load changes;
- 1 way power pulse output.

3 Structural features and operating principle

The structure adopts universal electric energy meter design, which is convenient to install and has strong versatility.

The MCU samples the input signal in real time, performs data processing on the sampling result and displays it, and communicates with the host computer through the RS485 interface to realize networking, and can also communicate with the host computer or the handheld device through the infrared communication interface.

4 Key technical parameters

4.1 Key technical parameters

The key technical parameters of this instrument are shown in Table 1.

Table 1 Key Technical Parameters

Technical parameters		Parameters	
Accuracy class	Voltage	Class 0.5	
	Current	Class 0.5	
	Energy	Class 1	
Input	Measurement signal		2 channels DC voltage and 2 channels DC current
	Voltage	Input scope	DC 0~750V
		Linear measurement range	10%Un~120%Un (Un is rated voltage)
		Power consumption	< 0.5W
	Current	Input scope	DC shunt input current: (Chosen by customer) DC shunt output voltage: 75mV
		Linear measurement range	1%In~120%In (In is rated current)
		Power consumption	< 0.5W
Display	Displaying method	LCD displaying	
Power supply	Voltage scope	DC +12V /+24V	
	Power consumption	≤2W	
Ambient temperature	Temperature	-25°C~+55°C for operating and -40°C~+70°C for storage	

	Humidity	$\leq 95\%RH$, no condensation and corrosive gases
--	----------	-----------------------------------------------------

4.2 Pulse output

The instrument has 2 channels electric energy pulse output, and the output mode is the open collector optocoupler output. The open collector voltage is $VCC \leq 48V$, the current $I_Z \leq 50mA$, and the pulse width should meet the requirements of $80ms \pm 20ms$.

5 Outline dimension

The outline dimension of this instrument is shown in Figure 1

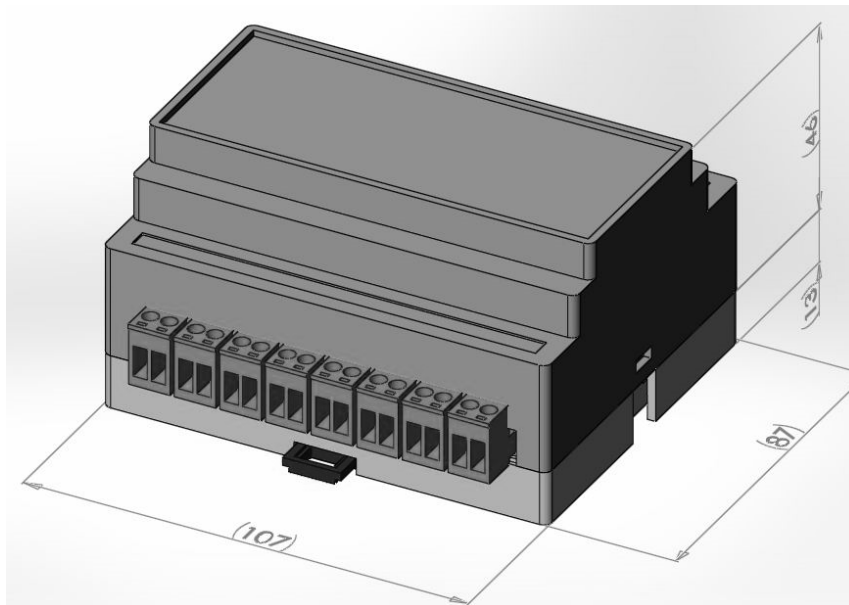

Figure 1 Outline dimension

6 Installation and usage

6.1 Installation method

The instrument is lead rail mounted.

6.2 Installation precautions

- The product shall be installed in a dry, well ventilated place away from heat and strong electricity (magnetic) fields.
- Working ambient temperature: $-25^{\circ}C \sim +55^{\circ}C$, humidity: $\leq 95\%$ (without condensation).

- It must be installed securely to prevent safety accidents caused by vibration.
- Sufficient space shall be reserved around the installation location considering the convenience and safety for installation and maintenance operations.
- Due to the convenience and safety of installation and maintenance operations, sufficient space should be left around the installation location of the instrument;
- Electrical wiring requirements: 1.5mm² shielded twisted pair is recommended for the DC shunt mV signal output wiring. The distance between the shunt and the instrument should not be too long. It is recommended that the line length be within 1m. The voltage input line and power line should be 1.5mm² multi-strand flame-retardant copper wire; 1.0mm² shielded twisted pair is used for RS485 communication;
- Electrical connection requirements: It is recommended to connect a suitable fuse (such as 1A fuse) to the instrument voltage input circuit.

6.3 Wiring

6.3.1 Terminals definition

Wiring terminals diagram of this instrument is shown in Figure 2 and wiring terminals definition is shown in Table 2.

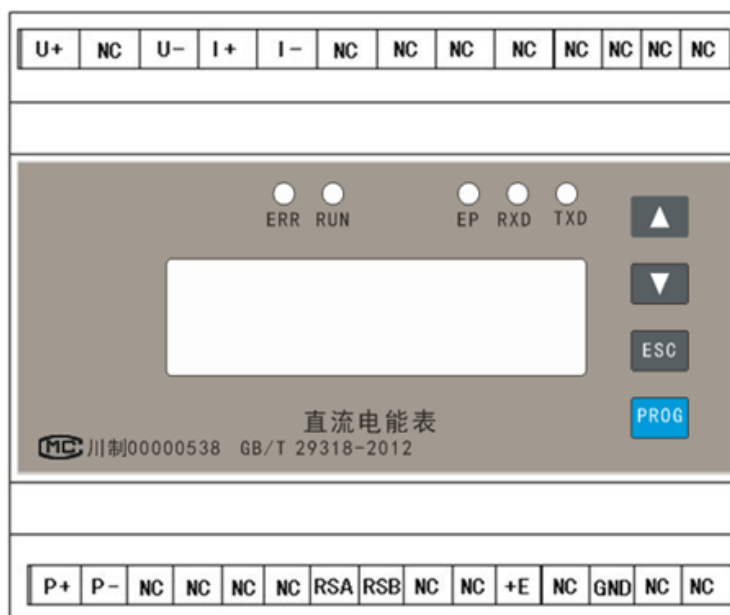
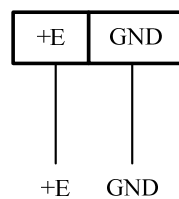

Figure 2 Outline of the instrument

Table 2 Wiring terminals definition

Function code	Description
+E	Power supply positive terminal
GND	Power supply ground terminal
RSA	RS485communication interface terminal A
RSB	RS485communication interface terminal B
U1+	Positive voltage output of Circuit 1
U1-	Negative voltage output of Circuit 1
I1+	mV Positive current input of Circuit 1
I1-	mV Negative current input of Circuit 1
U2+	Positive voltage output of Circuit 2
U2-	Negative voltage output of Circuit 2
I2+	mV Positive current input of Circuit 2
I2-	mV Negative current input of Circuit 2
P1+	Positive pulse output of Circuit 1
P1-	Negative pulse output of Circuit 1
P2+	Positive pulse output of Circuit 2
P2-	Negative pulse output of Circuit 2
NC	Unused.

6.3.2 Power supply wiring



Warning

In any case, please ensure that the power supply provided is suitable for this series of products to prevent product damage.

Figure 3 Power supply wiring

6.3.3 Communication wiring

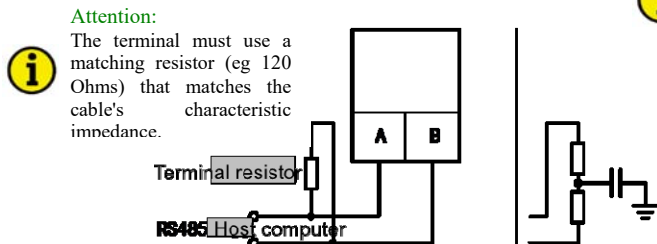

Attention:
The terminal must use a matching resistor (eg 120 Ohms) that matches the cable's characteristic impedance.



Attention:

For the case of working in severe electromagnetic interference conditions and transmission at high transmission rates, we recommend to use the "breaking terminal method". For example, the matching resistor is broken into two parts of 2*60 Ohms by means of a (10-100nF) capacitor that grounds the center tap.

Figure 4 Communication wiring

**Attention**

Twisted pair cables are recommended.

If a low-quality cable is used, the bus will have high contact resistance or other unfavorable factors, and the maximum length of the communication bus wiring may not be reached. Lowering the baud rate may solve the problem.

6.3.4 Input wiring

Figure 5 Input signals wiring

**Warning**

- The rated input voltage shall not be higher than the rated input voltage of the equipment; terminal block is recommended in consideration of maintenance and 1A fuse is recommended in the voltage input terminal of the instrument;

**Attention**

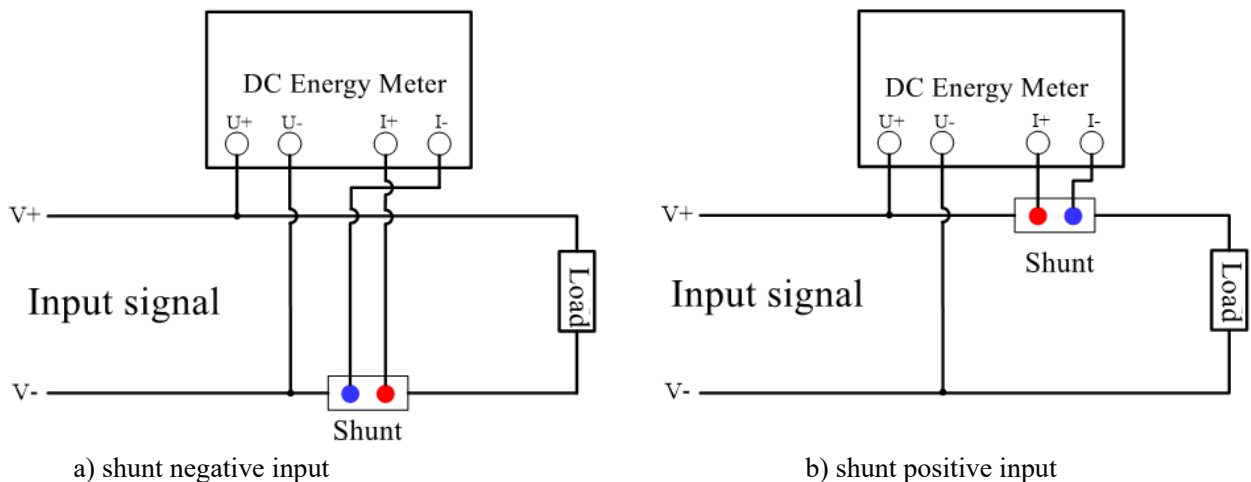
- The shunt should be connected to negative pole;
- The wiring method on site must be consistent with the product configuration and the input voltage and current are in the same direction as the wiring diagram. Otherwise, the equipment may not function properly or even be damaged.

6.3.5 Energy pulse output wiring

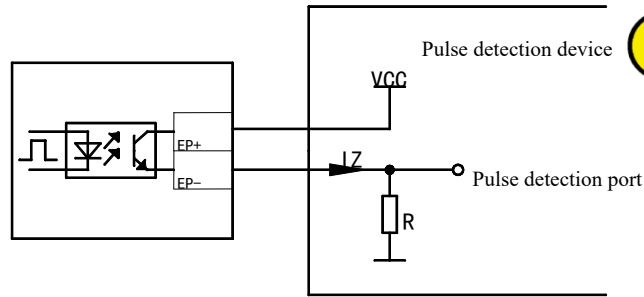

Attention

The pulse output is the open output of the optocoupler collector. Please ensure $VCC \leq 48V$ and $I_Z \leq 12mA$ during use to prevent damage to the pulse output port of the product.

Figure 6 Energy pulse output wiring

6.4 Usage

6.4.1 Panel description

Displaying panel is seen in Figure 7. Displaying panel description is seen in Table 3.



Figure 7 Displaying panel

Table 3 Displaying panel description

Identification	Description	Identification	Description
CH1	Parameter display indicator light of circuit 1	CH2	Parameter display indicator light of circuit 2
ERR	Hardware failure alarm	RUN	Product operating indicator light
EP1	Pulse output indicator light of circuit 1	EP2	Pulse output indicator light of circuit 2
RXD	Communication receiving indicator light	TXD	Communication sending indicator light
▲	Up/Accumulation button	▼	Down/cursor move button (press and hold this button, meanwhile operate the



			▲ button to reduce the function)
ESC	Return button	PROG	Enter button

6.4.2 Button description

Up button ▲: Used for measurement value display and programming menu switching; when editing parameter, used to realize the addition of parameter values, and if press this button for long time, the parameter value can be quickly accumulated. When you press the down button for a long time, you can operate the button to reduce the parameter value. If you press this button for a long time at the same time, the parameter value is quickly reduced.

Down button ▼: Used for measurement value display and programming menu switching; when the parameter is edited, the cursor is shifted. Press and hold this button at the same time, the up button can be operated to reduce the parameter value. If the up button is pressed for a long time at the same time, the parameter value is quickly reduced.

Return button ESC: Used to return to the main battery display when the measured value display mode is used; the programming mode is used to cancel the set parameter value and return to the upper menu step by step until the measured value display status.

Programming button PROG: used to enter the programming mode and go deep into the menu step by step until the parameter value is modified. After modifying the parameter value, it is used to save the parameter value and return to the previous menu.

6.4.3 Battery display

The user can set the wheel display time to realize the parameter wheel display, and also can switch the display parameters by using the up button and the down button. In this mode, long press the PROG button to return to the first screen display. The display parameters of the DC energy meter are shown in Table 4.

Table 4 Battery display

No. of display screen	Display content
1	Voltage of circuit 1



2	Current of circuit 1
3	Power of circuit 1
4	Energy of circuit 1
5	Voltage of circuit 2
6	Current of circuit 2
7	Power of circuit 2
8	Energy of circuit 2

6.4.4 Exception display

HHHH: The measured value is out of limit indication. If the input signal exceeds 1.2 times the rated value of the meter, the measured value shows the symbol.

The upper bar, the measured value is beyond the range that the meter can display.

When the product displays an abnormality, the communication data is still measured data.

6.4.5 Display configuration

The instrument has excellent programmability, which can be configured by keyboard operation or by communication. Before using the instrument officially, we recommend that the user configure it according to actual needs.

When programming with the keyboard, press the PROG key in the power display interface to enter the programming interface. Enter the programming password by turning up and down. If the password is correct, you can set the parameters. If the password is incorrect, you can only browse the parameters that have been set. **The initial product password is 1111.**

The instrument programming menu is divided into system class (Sys), communication class (Com), pulse class (puls), and clear class (Cler).

The programming parameters are shown in Table 5.

Table 5 Description of programming parameters

Parameter classification	Parameter code	Parameter name	Description
System class	rdAt	Reading day	1-28
	Ct1	Current change of circuit 1	1-9999



	Ct2	Current change of circuit 2	1-9999
	poll	Parameter wheel time interval	0-20, no round robin if less than 4
	FEI1	Period 1 hour, minute, rate number setting	1: sharp; 2: peak; 3: flat; 4: valley
	FEI2	Period 2 hour, minute, rate number setting	
	FEI3	Period 3 hour, minute, rate number setting	
	FEI4	Period 4 hour, minute, rate number setting	
	dAtE	Date setting	
	tInE	Time setting	
	stAt	Starting current setting	10~60
	CodE	User password setting	0-9999
	IA	Current rating setting	1~1000
	prtC	Communication protocol	rtu: MODBUS-RTU; dlt: DL/T645-2007
Communi- cation class	Addr	Communication address	1-247
	bAud	Communication baud rate	1200, 2400, 4800, 9600, 19200, 38400
	Chek	Bit format	no 2: no parity 2stop bit; odd 1: odd parity 1stop bit; eve 1: eve 1stop bit; no 1: no parity 1stop bit
Pulse class	Inp1	Pulse constant of circuit 1	Maximum pulse constant=3*10 ⁷ /rated power
	Inp2	Pulse constant of circuit 2	Maximum pulse constant=3*10 ⁷ /rated power
Clear class	Eng	Clear power	0x01: clearing data of channel 1; 0x02: clearing data of channel 2; 0x03: clearing all data.
	Anal	Clear value	1: clearing value of channel 1; 2: clearing value of channel 2; 3: clearing value of channel 3.

Remark: Current rating × current ratio = shunt rating value.

When the product is DL/T 645 protocol, it is recommended to set the product current rating to be less than or equal to 100A.

7. Communication protocol

DJS5169 Electronic DC Energy Meter provides serial half-duplex RS485 communication interface. MODBUS-RTU and DL/T645-2007 are adaptive to each other, and various data messages



can be transmitted on the communication line. Up to 64 instruments can be connected simultaneously on one line, and each meter can set its communication address.

The communication connection should use a shielded twisted pair with a copper mesh with a wire diameter of not less than 1.0 mm². When wiring the lines, the communication line shall be kept away from strong electrical cables or other strong electric fields.

7.1 MODBUS-RTU protocol

7.1.1 Summary

The MODBUS protocol uses a master-slave response mode of communication connection on a communication line. First, the signal of the host computer is addressed to a terminal device (slave) with a unique address, and then the response signal from the terminal device is transmitted to the host in the opposite direction, i.e., the signal along a separate communication line. The opposite direction transmits all communication data streams (half-duplex mode of operation).

The MODBUS protocol only allows communication between the host (PC, PLC, etc.) and the terminal device, and does not allow data exchange between independent terminal devices, so that each terminal device does not occupy the communication line when they initialize, but only responds the signal arriving to the machine.

Host Computer Query: The query message frame includes the device address, function code, data information code, and calibration code. The address code indicates the slave device to be selected; the function code tells the selected slave device which function to perform, for example, function code 0x03 is to ask the slave device to read the register and return their contents; the data segment contains the slave device to perform the function. Any additional information, such as in the read command, the additional information of the data segment has the number of registers from which to start reading and the number of registers to be read; the check code is used to verify the correctness of a frame of information, and the slave device provides a verification message content. Is it the correct method, it uses the calibration rules of CRC16.

Slave response: If the slave generates a normal response, the response message has a slave



address code, a function code, a data message code, and a CRC16 check code. The data information code includes data collected from the device: such as register values or status. If an error occurs, we agree that the slave does not respond.

The transmission method refers to a series of independent data structures within a data frame and limited rules for transmitting data. The following describes the transmission mode compatible with the RTU mode of the MODBUS protocol. Each data frame includes 1 start bit, 1 function bit, 8 data bits, (parity bit), 1 stop bit (when there is a check), 2 stop bits (when there is no check). The structure of the data frame: that is, the message format.

Address code	Function code	Data code	Check code
1 BYTE	1 BYTE	N BYTES	2 BYTES

The address code is composed of one byte (8-bit binary code) at the beginning of the frame, and the decimal is 0 to 255. In our system, only 1 to 247 are used, and other addresses are reserved. These bits indicate the address of the user-specified terminal device that will receive the host data from it. The address of each terminal device must be unique, and only the addressed terminal will respond to the query containing the address. When the terminal sends back the slave address data in a response, it tells the host which terminal is communicating with it.

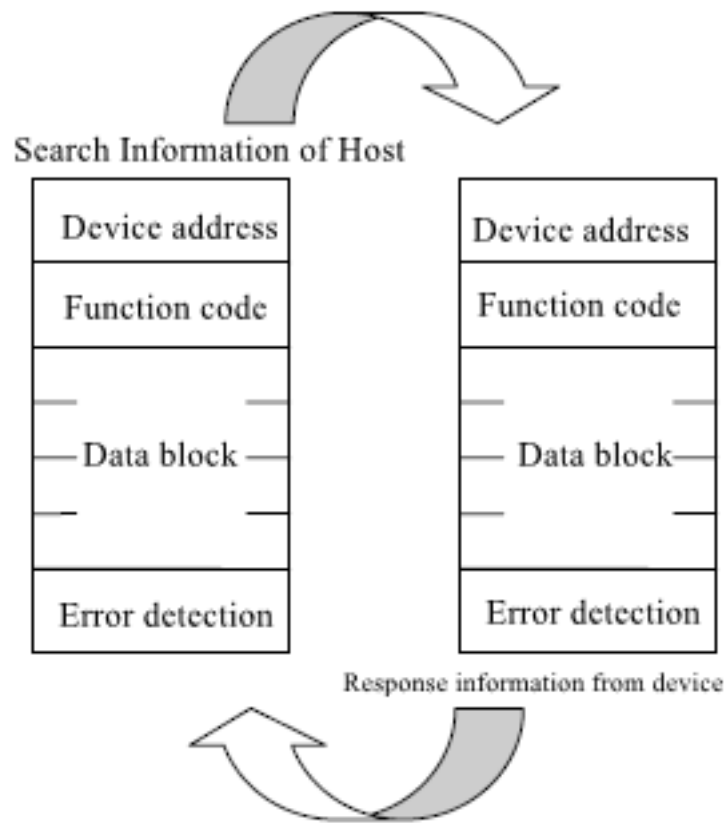

Figure 8 Schematic diagram of query response

7.1.2 Function code description

The function code tells the terminal which terminal is performing what function. The following table lists the function codes, their meaning and function supported by the meter.

Code	Meaning	Action
0x03	Read data register	Get one or more register values inside the current meter
0x05	Switching output control	Controls a relay inside the current meter
0x10	Set multiple registers	Write the specified value to 1 or more registers inside the meter

The data code contains the data required by the terminal to perform a specific function or the data collected by the terminal in response to the query. The contents of these data may be numeric values, reference addresses, or set values. For example, the function field code tells the terminal to read a register, the data field needs to indicate which register to start and how many data to read, and the slave data code returns the data length and corresponding data.

The Check Code Error Check (CRC) field occupies two bytes and contains a 16-bit binary



value. The CRC value is calculated by the transmitting device and then appended to the data frame. The receiving device recalculates the CRC value when receiving the data, and then compares it with the value in the received CRC field. If the two values are not equal, error occurs.

The process of generating a CRC is:

1. Preset a 16-bit register to 0FFFFH (all 1), which is called CRC register.
2. XOR the 8 bits of the first byte in the data frame with the low byte in the CRC register and store the result in the CRC register.
3. Move the CRC register one bit to the right, fill the highest bit with 0, and the lowest shift out and detect. If the least significant bit is 0: repeat the third step (next shift); if the lowest bit is 1: the XOR register is XORed with a preset fixed value (0A001H).
4. Repeat steps 3 and 4 until 8 shifts. This completes a complete eight bit.
5. Repeat steps 2 through 5 to process the next eight bits until all byte processing ends.
6. The value of the final CRC register is the value of the CRC.

7.1.3 Abnormal response

When the meter detects an error other than the CRC check code error, it will send back information to the host. The highest position of the function code is 1, that is, the function code returned by the slave to the host is based on the function code sent by the host. 128. The format of the error message returned by the slave is as follows:

Address code	Function code (highest byte is 1)	Error code	CRC check code low byte	CRC check code high byte
1byte	1byte	1byte	1byte	1byte

The error code is as follows:

01H	Illegal function code	Received function code meter does not support
02H	Illegal register address	The received register address is outside the instrument's register address range
03H	Illegal data value	The received data value exceeds the data range of the corresponding address

7.1.4 Example of communication messages

**7.1.4.1 Read register (Function Code 0x03)**

The package request to read the register is sent by the master station, and the device responds to all valid registers (between the start register and the end register). The message format is as follows:

Read register wrap format (host→device)		Response format (device→host)	
Slave address	1 byte	Slave address	1 byte
Function code 03H	1 byte	Function code 03H	1 byte
Start Address	2 bytes	Bytes (2*Number of Registers)	1 byte
Number of registers	2 bytes	First register data	2 bytes
CRC check code	2 bytes	Second register data	2 bytes
	
		CRC check code	2 bytes

7.1.4.2 relay control (function code 0x05)

Control relay format (host→device)		Response format (device→host)	
Slave address	1 byte	Slave address	1 byte
Function code 05H	1 byte	Function code 05H	1 byte
Channel address	2 bytes	Channel address	2 bytes
Control instruction	2 bytes	Control instruction	2 bytes
CRC check code	2 bytes	CRC check code	2 bytes

Remark: Channel address: 7000; Control command: 0xFF00 control relay is closed, 0x0000 control relay is released.

7.1.4.3 Reserve 1 or more registers (function code 0x10)

This command allows the master to configure device operating parameters. The following is the data format:

Read register wrap format (host→device)		Response format (device→host)	
Slave address	1 byte	Slave address	1 byte
Function code 10H	1 byte	Function code 10H	1 byte
Start address	2 bytes	Start address	2 bytes



Number of registers	2 bytes		Number of registers	2 bytes
Bytes no. (2*no. of registers)	1 byte		CRC check code	2 bytes
First register data	2 bytes			
.....			
CRC check code	2 bytes			

Description: Allows the customer to write setting data to the meter according to the Modbus protocol via the RS485 interface. The data address to be written must be a parameterizable address (reference parameter setting); if the address is not set, the write operation is invalid. In order to enhance the security and reliability of the instrument, the written data must be set with the package password (0x0816).

For example, the data frame is written as follows:

Meter address	Command	Start address	Data length	Byte length	Data (First 2 bytes are package password)	CRC16 low	CRC16 high
01H	10H	00H 1CH	00H 02H	04H	08H 16H 00H 01H	D0H	92H

7.1.4.4 Communication settings interface password description

Meter address	Command	Start address	Data length	Byte length	Data (package password)	Interface set old password	Interface set new password	CRC16 low	CRC16 high
01H	10H	03H 84H	00H 03H	06H	08H 16H	xxH xxH	xxH xxH	xxH	xxH

7.1.5 Parameter register table

The instrument has excellent programmability. The parameters of the specific configuration are shown in Table 6. Before the instrument is officially used, we recommend that the user configure it according to actual needs.

Table 6 Basic Configuration Data Register Table

No.	Register	Name	Description	Default value	attribute
1	6000	User password	0000~9999	1111	WO



2	6001	Communication address	1~247	1	RW
3	6002	Communication baud rate	0:1200bps; 1:2400bps; 2:4800bps; 3:9600bps; 4:19200bps; 5:38400bps	3	RW
4	6003	Bit format	0: no parity 2stop bit; 1: odd parity 1stop bit; 2: even parity 1stop bit; 3: no parity 1stop bit	3	RW
5	6004	Reading day	1~28	28	RW
6	6005	Current change of circuit 1	1~9999	1	RW
7	6006	Current change of circuit 2	1~9999	1	RW
8	6007	Parameter wheel display time	0~20s, no wheel display for less than 4s	5	RW
9	6008	Period 1 time	Time	1:00	RW
10	6009	Period 1 rate no.	1: sharp; 2: peak; 3: flat; 4: valley	1	RW
11	6010	Period 2 time	Time	7:00	RW
12	6011	Period 2 rate no.	1: sharp; 2: peak; 3: flat; 4: valley	2	RW
13	6012	Period 3 time	Time	13:00	RW
14	6013	Period 3 rate no.	1: sharp; 2: peak; 3: flat; 4: valley	3	RW
15	6014	Period 4 time	Time	19:00	RW
16	6015	Period 4 rate no.	1: sharp; 2: peak; 3: flat; 4: valley	4	RW
17	6016	Pulse Constant	See note 1		RW
18	6017	Reserved			
19	6018	Starting current	10~60	10	RW

Note 1: Energy meter pulse $C = (2 \sim 3) \times 107 / (U_n I_{max})$

Where: C—electric energy meter pulse constant;

U_n —reference voltage, V;

I_{max} - maximum current, A;

T—time interval, 1h.

The meter has the function of clearing power and maximum value. The corresponding operation registers are shown in Table 7.

Table 7 Clear Register Table

No.	Register	Name	Description	Default value	attribute
1	6500	Clear energy command	1: clear energy of circuit 1; 2: clear energy of circuit 2; 3: clear all energy.	0	RW
2	6501	Clear maximum value command	1: Clear maximum value of circuit 1; 2: Clear maximum value of circuit 2; 3: Clear all maximum values.	0	RW

Description: The clear command only supports single register operations.



Attention

After the data is cleared, it cannot be recovered. Please be cautious.

The real-time measurement data registers of the meter are shown in Table 8.

Table 8 Real-time measurement data register table

No.	Register	Name	Data classification	Unit	attribute
1	0	Low voltage of circuit 1	INT32	0.01V	RO
2	1	High voltage of circuit 1			
3	2	Low voltage of circuit 2	INT32	0.01V	RO
4	3	High voltage of circuit 2			
5	4	Low current of circuit 1	INT32	0.001A	RO
6	5	High current of circuit 1			
7	6	Low current of circuit 2	INT32	0.001A	RO
8	7	High current of circuit 2			
9	8	Low power of circuit 1	INT32	0.1W	RO
10	9	High power of circuit 1			
11	10	Positive low energy of circuit 2	INT32	0.1W	RO
12	11	Positive high energy of circuit 2			
13	12	Positive low energy of circuit 1	UINT32	0.01kWh	RO
14	13	Positive high energy of circuit 1			



15	14	Positive low energy of circuit 2	UINT32	0.01kWh	RO
16	15	Positive high energy of circuit 2			

Due to the limitation of the numerical range, many data registers of the product use a calculation factor, which means that if the user wants to get the real value, he must multiply the corresponding calculation factor.

For example, the calculation factor of the voltage register is 0.01, and if the value read by the user is 5000, the current voltage is: $5000 \times 0.01 = 50V$;

All the power data read by the communication are secondary values (except for the electric energy), and there is no conversion ratio. The specific conversion method is shown in Table 9.

Table 9 output data conversion

No.	Content	Communication value	Actual value
1	Current	Secondary side	communication value \times calculation factor \times CT
2	Power	Secondary side	communication value \times calculation factor \times CT
3	others	Secondary side	communication value \times calculation factor

Table 10 Time Data Area Register Table

Register	Name	Data classification	Attribute	Description
1000	Year	UINT16	RW	YY
1001	Month		RW	MM
1002	Day		RW	DD
1003	Hour		RW	hh
1004	Minute		RW	mm
1005	Second		RW	ss
1006	Week		RW	ww

Table 11 Event Record Data Register Table

No.	Register	Name	Data classification	Description
-----	----------	------	---------------------	-------------



1	1200	Total power down times		UINT16	
2	1201	Fault alarm		UINT16	Bit0: Fram hardware failure; Bit1: Flash hardware failure; Bit2: battery voltage shortage alarm. 1 indicates for alarm, 0 indicates for normal.
3	1202	Checking time record	Checking time times	UINT16	
4	1203		Year、month	UINT16	Time of last Checking time
5	1204		Day、hour	UINT16	
6	1205		Min.、Second	UINT16	
7	1206	Clearing energy record	Clear energy times	UINT16	
8	1207		Clear energy mode	UINT16	1: clear data of circuit 1; 2: clear data of circuit 2; 3: clear all data.
9	1208		Year、month	UINT16	Time of last clearing energy
10	1209		Day、hour	UINT16	
11	1210		Min.、Second	UINT16	
12	1211	Clearing max. value record	Clearing max. value times	UINT16	
13	1212		Clearing max. value mode	UINT16	1: clear data of circuit 1; 2: clear data of circuit 2; 3: clear all data.
14	1213		Year、month	UINT16	Time of last clearing energy
15	1214		Day、hour	UINT16	
16	1215		Min.、	UINT16	



			Second		
--	--	--	--------	--	--

Table 12 Total energy data register area

No.	Register	Name	Data classification	Unit	Attribute
1	2000	Positive low energy of circuit 1	UINT32	0.01kWh	RO
2	2001	Positive high energy circuit 1			
Reserved					
5	2004	Positive low energy in Jan. of circuit 1	UINT32	0.01kWh	RO
6	2005	Positive high energy in Jan. of circuit 1			
7	2006	Positive low energy in Feb. of circuit 1	UINT32	0.01kWh	RO
8	2007	Positive high energy in Feb. of circuit 1			
9	2008	Positive low energy in Mar. of circuit 1	UINT32	0.01kWh	RO
10	2009	Positive high energy in Mar. of circuit 1			
11	2010	Positive low energy in Apr. of circuit 1	UINT32	0.01kWh	RO
12	2011	Positive high energy in Apr. of circuit 1			
13	2012	Positive low energy in May of circuit 1	UINT32	0.01kWh	RO
14	2013	Positive high energy in May of circuit 1			
15	2014	Positive low energy in Jun. of circuit 1	UINT32	0.01kWh	RO
16	2015	Positive high energy in Jun. of circuit 1			



		circuit 1			
17	2016	Positive low energy in Jul. of circuit 1	UINT32	0.01kWh	RO
18	2017	Positive high energy in Jul. of circuit 1			
19	2018	Positive low energy in Aug. of circuit 1	UINT32	0.01kWh	RO
20	2019	Positive high energy in Aug. of circuit 1			
21	2020	Positive low energy in Sep. of circuit 1	UINT32	0.01kWh	RO
22	2021	Positive high energy in Sep. of circuit 1			
23	2022	Positive low energy in Oct. of circuit 1	UINT32	0.01kWh	RO
24	2023	Positive high energy in Oct. of circuit 1			
25	2024	Positive low energy in Nov. of circuit 1	UINT32	0.01kWh	RO
26	2025	Positive high energy in Nov. of circuit 1			
27	2026	Positive low energy in Dec. of circuit 1	UINT32	0.01kWh	RO
28	2027	Positive high energy in Dec. of circuit 1			
Reserved					
53	2052	Positive low energy of circuit 1	UINT32	0.01kWh	RO
54	2053	Positive high energy of circuit 1			
55	2054	Positive low energy of circuit 1	UINT32	0.01kWh	RO



56	2055	Positive high energy of circuit 1			
57	2056	Positive low energy of circuit 1	UINT32	0.01kWh	RO
58	2057	Positive high energy of circuit 1			
59	2058	Positive low energy of circuit 1	UINT32	0.01kWh	RO
60	2059	Positive high energy of circuit 1			
Reserved					
69	2068	Positive low energy of circuit 2	UINT32	0.01kWh	RO
70	2069	Positive high energy circuit 2			
Reserved					
73	2072	Positive low energy in Jan. of circuit 2	UINT32	0.01kWh	RO
74	2073	Positive high energy in Jan. of circuit 2			
75	2074	Positive low energy in Feb. of circuit 2	UINT32	0.01kWh	RO
76	2075	Positive high energy in Feb. of circuit 2			
77	2076	Positive low energy in Mar. of circuit 2	UINT32	0.01kWh	RO
78	2077	Positive high energy in Mar. of circuit 2			
79	2078	Positive low energy in Apr. of circuit 2	UINT32	0.01kWh	RO
80	2079	Positive high energy in Apr. of circuit 2			



81	2080	Positive low energy in May of circuit 2	UINT32	0.01kWh	RO
82	2081	Positive high energy in May of circuit 2			
83	2082	Positive low energy in Jun. of circuit 2	UINT32	0.01kWh	RO
84	2083	Positive high energy in Jun. of circuit 2			
85	2084	Positive low energy in Jul. of circuit 2	UINT32	0.01kWh	RO
86	2085	Positive high energy in Jul. of circuit 2			
87	2086	Positive low energy in Aug. of circuit 2	UINT32	0.01kWh	RO
88	2087	Positive high energy in Aug. of circuit 2			
89	2088	Positive low energy in Sep. of circuit 2	UINT32	0.01kWh	RO
90	2089	Positive high energy in Sep. of circuit 2			
91	2090	Positive low energy in Oct. of circuit 2	UINT32	0.01kWh	RO
92	2091	Positive high energy in Oct. of circuit 2			
93	2092	Positive low energy in Nov. of circuit 2	UINT32	0.01kWh	RO
94	2093	Positive high energy in Nov. of circuit 2			
95	2094	Positive low energy in Dec. of circuit 2	UINT32	0.01kWh	RO
96	2095	Positive high energy in Dec. of circuit 2			



Reserved					
121	2120	Positive low energy of circuit 2	UINT32	0.01kWh	RO
122	2121	Positive high energy of circuit 2			
123	2122	Positive low energy of circuit 2	UINT32	0.01kWh	RO
124	2123	Positive high energy of circuit 2			
125	2124	Positive low energy of circuit 2	UINT32	0.01kWh	RO
126	2125	Positive high energy of circuit 2			
127	2126	Positive low energy of circuit 2	UINT32	0.01kWh	RO
128	2127	Positive high energy of circuit 2			
Reserved					

Table 13 Max. value register

No.	Register	Name		Data classification	Unit	Attribute
1	3000	Max. positive low voltage of circuit 1		UINT32	0.01V	RO
2	3001	Max. positive high voltage of circuit 1				
3	3002	Time of max.	Year、month	UINT16	1	RO
4	3003	positive voltage	Day、hour	UINT16	1	RO
5	3004	value of circuit 1	Min.、	UINT16	1	RO



			second			
6	3005	Max. positive low voltage of circuit 2		UINT32	0.01V	RO
7	3006	Max. positive low voltage of circuit 2				
8	3007	Time of max.	Year、month	UINT16	1	RO
9	3008	positive voltage	Day、hour	UINT16	1	RO
10	3009	value of circuit 2	Min.、second	UINT16	1	RO
11	3010	Max. positive low current of circuit 1		UINT32	0.001A	RO
12	3011	Max. positive high current of circuit 1				
13	3012	Time of max.	Year、month	UINT16	1	RO
14	3013	positive current	Day、hour	UINT16	1	RO
15	3014	value of circuit 1	Min.、second	UINT16	1	RO
16	3015	Max. positive low current of circuit 2		UINT32	0.001A	RO
17	3016	Max. positive high current of circuit 2				
18	3017	Time of max.	Year、month	UINT16	1	RO
19	3018	positive current	Day、hour	UINT16	1	RO
20	3019	value of circuit 2	Min.、second	UINT16	1	RO
21	3020	Max. positive low power of circuit 1		INT32	0.1W	RO



22	3021	Max. positive high power circuit 1				
23	3022	Time of max.	Year、month	UINT16	1	RO
24	3023	positive power value circuit 1	Day、hour	UINT16	1	RO
25	3024		Min.、second	UINT16	1	RO
26	3025		Max. positive low power of circuit 2		INT32	0.1W
27	3026	Max. positive high power circuit 2				
28	3027	Time of max.	Year、month	UINT16	1	RO
29	3028	positive power value circuit 2	Day、hour	UINT16	1	RO
30	3029		Min.、second	UINT16	1	RO
31	3030	Min. positive low voltage of circuit 1		UINT32	0.01V	RO
32	3031	Min. positive high voltage of circuit 1				
33	3032	Time of min.	Year、month	UINT16	1	RO
34	3033	positive voltage value of circuit 1	Day、hour	UINT16	1	RO
35	3034		Min.、second	UINT16	1	RO
36	3035	Min. positive low voltage of circuit 2		UINT32	0.01V	RO
37	3036	Min. positive high voltage of circuit 2				
38	3037	Time of	Year、	UINT16	1	RO



		min.	month			
39	3038	positive voltage	Day、hour	UINT16	1	RO
40	3039	value of circuit 2	Min.、second	UINT16	1	RO
41	3040	Min. positive low current of circuit 1		UINT32	0.001A	RO
42	3041	Min. positive high current of circuit 1				
43	3042	Time of min.	Year、month	UINT16	1	RO
44	3043	positive current	Day、hour	UINT16	1	RO
45	3044	value of circuit 1	Min.、second	UINT16	1	RO
46	3045	Min. positive low current of circuit 2		UINT32	0.001A	RO
47	3046	Min. positive high current of circuit 2				
48	3047	Time of min.	Year、month	UINT16	1	RO
49	3048	positive current	Day、hour	UINT16	1	RO
50	3049	value of circuit 2	Min.、second	UINT16	1	RO
51	3050	Min. positive low power of circuit 1		INT32	0.1W	RO
52	3051	Min. positive high power of circuit 1				
53	3052	Time of min.	Year、month	UINT16	1	RO
54	3053	positive power	Day、hour	UINT16	1	RO



55	3054	value of circuit 1	Min., second	UINT16	1	RO
56	3055	Min. positive low power of circuit 2		INT32	0.1W	RO
57	3056	Min. positive high power of circuit 2				
58	3057	Time of min.	Year, month	UINT16	1	RO
59	3058	positive power	Day, hour	UINT16	1	RO
60	3059	value of circuit 2	Min., second	UINT16	1	RO

Note:

User password can be set, and the user password is invalid. User password is mainly used for interface setting parameters;

Six registers must be written at the same time, otherwise invalid.

It can only be used once a day, and the time difference cannot exceed 5 minutes each time;

When the broadcast address is timed, it is not restricted by the password, that is, there is no need to add a password when the school is in school.

7.2 DL/T645-2007 protocol**7.2.1 Summary**

The DL/T645-2007 protocol is a multi-function electric energy meter communication protocol, the protocol is a master-slave half-duplex communication method, the handheld unit or other data terminal is the main station, and the multi-function electric energy meter is the slave station, and each multi-function electric energy The tables have their own address codes.

7.2.2 Frame format

The establishment and cancellation of the communication link are controlled by the information frame sent by the primary station. Each frame consists of a frame start character, a



slave address field, a control code, a data field length, a data field, a frame information vertical check code, and a frame end character. The frame format is shown in Table 14.

Table 14 Frame format

Description	Code
Frame start character	68H
Address field	A0
	A1
	A2
	A3
	A4
	A5
Frame start character	68H
Control code	C
Data field length	L
Data field	DATA
Check code	CS
End character	16H

The address field consists of 6 bytes, 2 bits of BCD code per byte, and the address length can be up to 12 decimal digits. Each meter has a unique communication address. When the length of the used address code is less than 6 bytes, the high bit is complemented by "0".

The communication address 999999999999H is a broadcast address and is valid only for special commands, such as broadcast time. The broadcast command does not require a slave to answer.

When the address field is transmitted, the low byte is first and the high byte is after.

The control code is one byte and its format is shown in Figure 9.

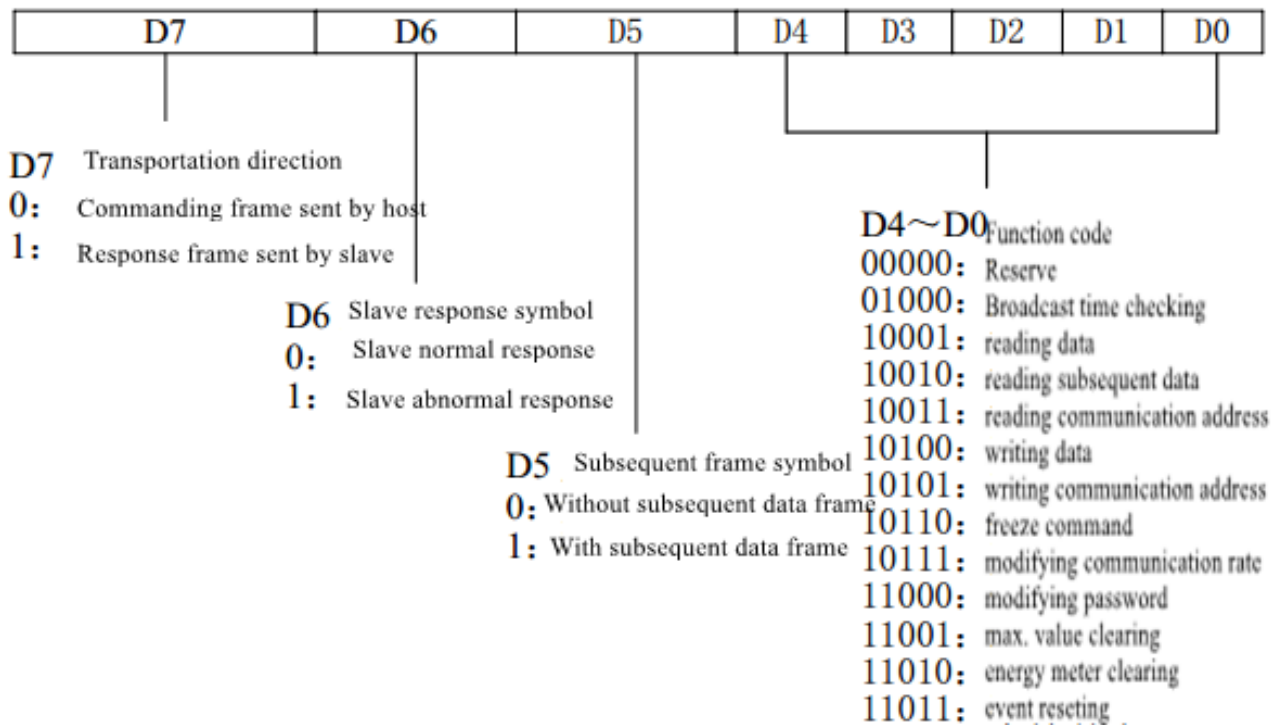

Figure 9 Control code format

The length L of the data field is the number of bytes, $L \leq 200$ when reading data, $L \leq 50$ when writing data, and $L = 0$ indicates no data field. The data field includes data identification, password, operator code, data, frame number, etc., and its structure changes with the function of the control code. When transmitting, the sender adds 33H to the byte, and the receiver subtracts 33H by byte.

The check code CS is the sum of the modulo 256 of all the bytes from the start of the first frame start to the check code, that is, the byte binary arithmetic sum, excluding the overflow value exceeding 256.

All data items are transmitted first with the low byte and then with the high byte.

7.2.3 Data identification

The data identification code uses four bytes to distinguish different data items. The four bytes are represented by DI3, DI2, DI1 and DI0, and each byte is encoded in hexadecimal.

The control codes and identification codes for reading and configuring related parameters are shown in Table 15 to Table 20.



Table 15 Basic registers

Name	Data format	Data length (byte)	Unit	Address	Identification code
Voltage of circuit 1	xxx.x	2	V	Addr	0x02010100
Voltage of circuit 2	xxx.x	2	V	Addr+1	0x02010100
Voltage data block	xxx.x	6	V	Addr/Addr+1	0x0201ff00
Current of circuit 1	xxx.xxx	3	A	Addr	0x02020100
Current of circuit 2	xxx.xxx	3	A	Addr+1	0x02020100
Current data block	xxx.xxx	9	A	Addr/Addr+1	0x0202ff00
Power of circuit 1	xx.xxxx	3	kW	Addr	0x02030100
Power of circuit 2	xx.xxxx	3	kW	Addr+1	0x02030100
Positive energy of circuit 1	xxxxxx.xx	4	kWh	Addr	0x00150000
Positive energy of circuit 2	xxxxxx.xx	4	kWh	Addr+1	0x00150000
Total positive energy of circuit 1	xxxxxx.xx	4	kWh	Addr	0x00010000
Total positive energy of circuit 2	xxxxxx.xx	4	kWh	Addr+1	0x00010000
Active energy data block	xxxxxx.xx	20	kWh	Addr	0x0000ff00
Active energy data block	xxxxxx.xx	20	kWh	Addr+1	0x0000ff00

Table 16 time data

Name	Data format	Data length (byte)	Unit	Address	Identification code
Year month day week	YYMMDDWW	4	1	Addr/ Addr+1	0x04000101
Hour minute second	Hhmmss	3	1	Addr/ Addr+1	0x04000102



Table 17 Event record data

Name	Data format	Data length (byte)	Unit	Address	Identification code
Total power down times	NNNNNN	3	time	Addr/ Addr+1	0x03110000
Hardware failure	NNNN	2	1	Addr/ Addr+1	0x03301002
Checking time times	NNNNNN	3	time	Addr/ Addr+1	0x03300400
Time of last Checking time	YYMMDDhhmmss	6	1	Addr/ Addr+1	0x03300401
Clearing energy times	NNNNNN	3	time	Addr/ Addr+1	0x03300100
Last clearing energy mode	NNNN	2	1	Addr/ Addr+1	0X03300110
Last clearing energy time	YYMMDDhhmmss	6	1	Addr/ Addr+1	0X03300101
Clearing max. value times	NNNNNN	3	1	Addr/ Addr+1	0X03300f00
Last clearing max. value mode	NNNN	2	1	Addr/ Addr+1	0X03300f10
Last clearing max. value time	YYMMDDhhmmss	6	1	Addr/ Addr+1	0X03300f11

Table 18 Energy data

Name	Data format	Data length (byte)	Unit	Address	Identification code
Energy data block from Jan. to Dec. of circuit 1	xxxxxx.xx Jan. is in the first, Dec. is in the last	48	kWh	Addr	0x00D00001
The 1 st positive active sharp energy of circuit 1	xxxxxx.xx	4	kWh	Addr	0x00010100
The 1 st positive active	xxxxxx.xx	4	kWh	Addr	0x00010200



peak energy of circuit 1					
The 1 st positive active flat energy of circuit 1	xxxxxx.xx	4	kWh	Addr	0x00010300
The 1 st positive active valley energy of circuit 1	xxxxxx.xx	4	kWh	Addr	0x00010400
Positive energy data block for 4 times of circuit 1	xxxxxx.xx sharp peak flat valley	16	kWh	Addr	0x0001ff00
Energy data block from Jan. to Dec. of circuit 2	xxxxxx.xx Jan. is in the first, Dec. is in the last	48	kWh	Addr+1	0x00D00001
The 1st positive active sharp energy of circuit 2	xxxxxx.xx	4	kWh	Addr+1	0x00010100
The 1st positive active peak energy of circuit 2	xxxxxx.xx	4	kWh	Addr+1	0x00010200
The 1st positive active flat energy of circuit 2	xxxxxx.xx	4	kWh	Addr+1	0x00010300
The 1st positive active valley energy of circuit 2	xxxxxx.xx	4	kWh	Addr+1	0x00010400
Positive energy data block for 4 times of circuit 2	xxxxxx.xx sharp peak flat valley	16	kWh	Addr+1	0x0001ff00

Table 19 Max. value data

Name	Data format	Data length (byte)	Unit	Address	Identification code
Max. voltage value and time of circuit 1	xxx.x YYNNDDhhmmss	8	V --	Addr	0x03101001
Max. current value and time of circuit 1	xxx.xxx YYNNDDhhmmss	9	A --	Addr	0x03101002
Max. power value	xx.xxxx	9	kW	Addr	0x03101003



and time of circuit 1	YYNNDDhhmmss		--		
Max. voltage value and time of circuit 2	xxx.x YYNNDDhhmmss	8	V --	Addr+1	0x03101001
Max. current value and time of circuit 2	xxx.xxx YYNNDDhhmmss	9	A --	Addr+1	0x03101002
Max. power value and time of circuit 2	xx.xxxx YYNNDDhhmmss	9	kW --	Addr+1	0x03101003
Min. voltage value and time of circuit 1	xxx.x YYNNDDhhmmss	8	V --	Addr	0x03101201
Min. current value and time of circuit 1	xxx.xxx YYNNDDhhmmss	9	A --	Addr	0x03101202
Min. power value and time of circuit 1	xx.xxxx YYNNDDhhmmss	9	kW --	Addr	0x03101203
Min. voltage value and time of circuit 2	xxx.x YYNNDDhhmmss	8	V --	Addr+1	0x03101201
Min. current value and time of circuit 2	xxx.xxx YYNNDDhhmmss	9	A --	Addr+1	0x03101202
Min. power value and time of circuit 2	xx.xxxx YYNNDDhhmmss	9	kW --	Addr+1	0x03101203

Table 20 configuration data

Control code	Name	Data format	Data length (byte)	Unit	Address	Identification code
0x08	Checking time	YYMMDDHHmmss	6			
0x13	Read communication address		0			
0x14	Year month day week	YYMMDDWW	4		Addr/Addr+1	0X04000101
0x14	Hour minute second	Hhmmss	3		Addr/Addr+1	0x04000102



0x14	Hour、minute、 no. of period 1 Hour、minute、 no. of period 4	HHmmNN HHmmNN	12		Addr/Addr+1	0x04010001
0x14	Automatic reading day	NNNN	2		Addr/Addr+1	0x04000109
0x14	Pulse constant of circuit 1	NNNNNN	3	imp/kwh	Addr	0x04000409
0x14	Pulse constant of circuit 2	NNNNNN	3	imp/kwh	Addr+1	0x04000409
0x14	Current change of circuit 1	NNNNNN	3		Addr	0x04000306
0x14	Current change of circuit 2	NNNNNN	3		Addr+1	0x04000306
0x14	Wheel display time	NN	1	second	Addr/Addr+1	0x04000302
0x14	Starting current	NNNN	2		Addr/Addr+1	0x04000410
0x15	Communication address	NNNNNNNNNNNN	6		Addr/Addr+1	----
0x17	Communication baud rate	NN	1		Addr/Addr+1	----
0x18	Displaying password	NNNNNNNN	4		Addr/Addr+1	0x04000c01
0x1a	Clearing energy command of circuit 1				Addr	
0x1a	Clearing energy command of circuit 2				Addr+1	
0x1b	Clearing max. value command of circuit 1				Addr	



0x1b	Clearing max. value command of circuit 2				Addr+1	
------	------------------------------------------------	--	--	--	--------	--

Remarks:

1. Addr is the set meter address;
2. Refer to Table 6 for the configuration range of configuration data.
3. All the power data read by the communication are secondary values (except for the electric energy), and there is no conversion ratio. The specific conversion method is shown in Table 9.

7.2.4 Communication packet description

7.2.4.1 Reading data

Master request frame

Function: Request to read the energy meter data

Function code: C=11H

Data field length: L=04H

Frame format:

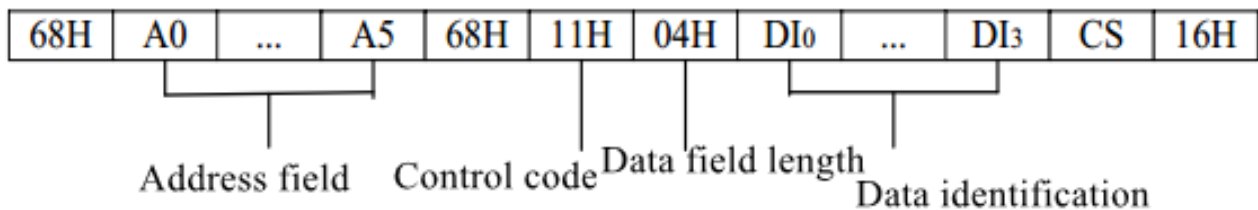

Slave normal response

Control code: C=91H

Data field length: L=04+m (data length)

Frame format:

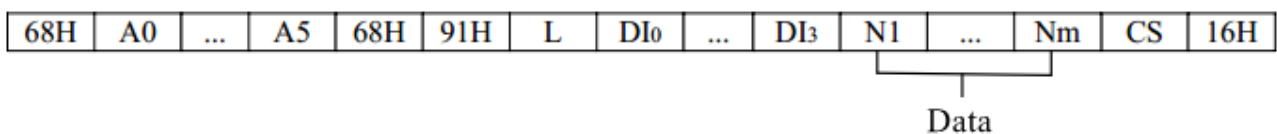

Slave normal response

Control code: C=D1H



Data field length: L=01H

Frame format:

68H	A0	...	A5	68H	D1H	01H	ERR	CS	16H
-----	----	-----	----	-----	-----	-----	-----	----	-----

Error information

Error information ERR

Bit7	Bit6	Bit5	Bit4	Bit3	Bit2	Bit1	Bit0
Reserve	Rate	Day hour	Year hour	Communication rate can't be changed	Passcode error/ Unauthorized	No data	Other errors

0 indicates occur without errors, 1 indicates occur with errors. Except the defined errors of Bit 1、2、3、4、5、6, and other situations belong to other errors of Bit 0.

7.2.4.2 Broadcast time checking

Function: Force time synchronization between slave and master.

Control code: C=08H

Data field length: L=06H

Data field: YYMMDDhhmmss(Year、month、day、hour、minute、second)

Frame format:

68H	99H	...	99H	68H	08H	06H	ss	mm	hh	DD	MM	YY	CS	16H
-----	-----	-----	-----	-----	-----	-----	----	----	----	----	----	----	----	-----

Second Minute Hour Day Month Year

Note:

- 1、 No answer is required during broadcast time checking.
- 2、 Execute the broadcast calibration command only when the date of the slave and the time difference between the slave and the master are within 5 min.
- 3、 It is not recommended to check at 0 o'clock at midnight, so as not to affect some routine operations at 0 o'clock.
- 4、 Only one time for time checking is allowed per day.

7.2.4.3 Writing data

Host request frame

Function: The host requests the setup data from the slave

Function code: C=14H



Code field length: $L=04H+04H$ (password) $+04H$ (operator code) $+m$ (data length)

Data field: $DI_0 DI_1 DI_2 DI_3+PAP0P1P2+C0C1C2C3+DATA$

Frame format:

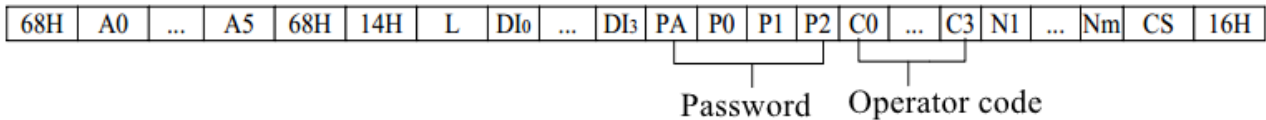

Slave normal response

Control code: $C=94H$

Data field length: $L=00H$

Frame format:

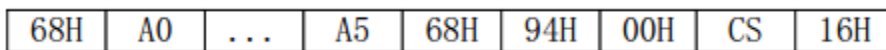

Slave abnormal response

Control code: $C=D4H$

Data field length: $L=01H$

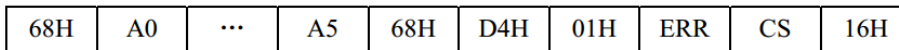

Note: all PAP0P1P2 are 0, all C0C1C2C3 are 0

7.2.4.4 Communication address modification

Host request frame

Function: set the communication address of a station, only support point to point

communication

Function code: $C=15H$

Address field: AAAAAAAAAAAAH

Data field length: $L=06H$

Data field: A0A1A2A3A4A5(communication address)

Frame format:

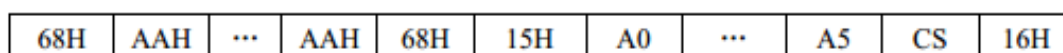

Slave normal response



Control code: C=95H

Address field: A0A1A2A3A4A5 new setting communication address

Data field length: L=00H

Frame format:

68H	A0	...	A5	68H	95H	00H	CS	16H
-----	----	-----	----	-----	-----	-----	----	-----

No response for slave abnormal situation

7.2.4.5 Communication baud rate

Host request frame

Function: current communication rate is changed to other standard rate.

Function code: C=17H

Data field length: L=01H

Frame format:

68H	A0	...	A5	68H	17H	01H	Z	CS	16H
-----	----	-----	----	-----	-----	-----	---	----	-----

Communication rate characteristic word

Slave normal response

Control code: C=97H

Data field length: L=01H

Frame format:

68H	A0	...	A5	68H	97H	01H	Z	CS	16H
-----	----	-----	----	-----	-----	-----	---	----	-----

Slave abnormal response

Control code: C=D7H

Data field length: L=01H

68H	A0	...	A5	68H	D7H	01H	ERR	CS	16H
-----	----	-----	----	-----	-----	-----	-----	----	-----

Communication rate characteristic word



Bit7	Bit6	Bit5	Bit4	Bit3	Bit2	Bit1	Bit0
Reserve	19200bps	9600bps	4800bps	2400bps	1200bps	600bps	Reserve

Note: 0 indicates non-current interface communication rate, 1 indicates current interface communication rate and characteristic word is only effective when one of the Bites is 1.

7.2.4.6 Modifying password

Host request frame

Function: modifying slave password

Note: 0 indicates non-current interface communication rate, 1 indicates current interface communication rate and characteristic word is only effective when one of the Bites is 1.

Function code: C=18H

Data field length: L=0CH

Data field: $DI_0 DI_1 DI_2 DI_3 + PA_0 P_0 P_1 P_2 + PA_N P_0 P_1 P_2$

Frame format:

68H	A0	...	A5	68H	18H	0CH	DI ₀	...	DI ₃	PA ₀	P ₀	P ₁	P ₂	PA _N	P _{0N}	P _{1N}	P _{2N}	CS	16H
-----	----	-----	----	-----	-----	-----	-----------------	-----	-----------------	-----------------	----------------	----------------	----------------	-----------------	-----------------	-----------------	-----------------	----	-----

$PA_0 P_0 P_1 P_2$ is original password, $PA_N P_0 P_1 P_2$ is new password.

Slave normal response

Control code: C=98H

Data field length: L=04H

Data field: $PA_N P_0 P_1 P_2$ (new password)

Frame format:

68H	A0	...	A5	68H	98H	04H	PA _N	P _{0N}	P _{1N}	P _{2N}	CS	16H
-----	----	-----	----	-----	-----	-----	-----------------	-----------------	-----------------	-----------------	----	-----

Slave abnormal response

Control code: C=D8H

Data field length: L=01H

68H	A0	...	A5	68H	19H	08H	PA	P0	P1	P2	C0	...	C3	CS	16H
-----	----	-----	----	-----	-----	-----	----	----	----	----	----	-----	----	----	-----

7.2.4.7 Clearing electric energy of meter

Host request frame

Function: empty electricity of energy meter



Function code: C=1aH

Data field length: L=08H

Data field: PAP0P1P2+ C0C1C2C3

Frame format:

68H	A0	...	A5	68H	1AH	08H	PA	P0	P1	P2	C0	...	C3	CS	16H
-----	----	-----	----	-----	-----	-----	----	----	----	----	----	-----	----	----	-----

Slave normal response

Control code: C=9AH

Data field length: L=00H

Frame format:

68H	A0	...	A5	68H	9AH	00H	CS	16H
-----	----	-----	----	-----	-----	-----	----	-----

Slave abnormal response

Control code: C=DAH

Data field length: L=01H

68H	A0	...	A5	68H	DAH	01H	ERR	CS	16H
-----	----	-----	----	-----	-----	-----	-----	----	-----

Note: all PAP0P1P2 are 0, all C0C1C2C3 are 0

7.2.4.8 Event reset

Host request frame

Function: empty the relevant event records such as the maximum value and minimum value stored in the energy meter

Function code: C=1BH

Data field length: L=0CH

Data field: PAP0P1P2+ C0C1C2C3+FFFFFFFF

Frame format:

68H	A0	...	A5	68H	1BH	0CH	PA	P0	P1	P2	C0	...	C3	FFH	FFH	FFH	FFH	CS	16H
-----	----	-----	----	-----	-----	-----	----	----	----	----	----	-----	----	-----	-----	-----	-----	----	-----

Slave normal response

Control code: C=9BH

Data field length: L=00H



Frame format:

68H	A0	...	A5	68H	9BH	00H	CS	16H
-----	----	-----	----	-----	-----	-----	----	-----

Slave abnormal response

Control code: C=DBH

Data field length: L=01H

68H	A0	...	A5	68H	DBH	01H	ERR	CS	16H
-----	----	-----	----	-----	-----	-----	-----	----	-----

Note: all PAP0P1P2 are 0, all C0C1C2C3 are 0.

8 Note

- a) The product needs to be warmed up for 3 minutes after it is powered on.
- b) The product should not be subjected to knocking, collision and severe vibration, and the use environment should meet the technical requirements.
- c) When the company's products are discarded, they cannot be recycled. Please contact the qualified recycling department for disposal.

9 After sales service

9.1 New product quality assurance

All new products sold to users are subject to free quality assurance for failures resulted in by design, materials and workmanship defects within One Year from the date of selling to the user. We will repair and replace the product free of charge if it is found to meet above warranty conditions.

We may ask the user to return the product to the manufacturer to confirm whether the product belongs to the free warranty and to repair it.

9.2 Product warranty limit

Free warranty does not include the products caused by the following problems:

- Damage caused by improper installation, usage and storage;
- Exceeding the abnormal operation and application conditions regulated by the



product;

- Products which have been repaired not by the company or not by an organization or person authorized by the company;
- Products which have exceeded the free warranty period.

10 Package, transportation and storage

10.1 Storage

The package of the product shall meet the requirements of environment protection and the package requirements shall comply with the regulations of GB/T 15464-1995.

10.2 Transportation and storage

The transportation and storage of the product shall comply with the regulations of JB/T 9329-1999. The ambient temperature for storage is $-40^{\circ}\text{C}\sim 70^{\circ}\text{C}$, and relative humidity is not more than 95%. Meanwhile, the hazardous substances contained in the air are not enough to cause corrosion for the product.

Complimentary clause

- This is the end of the instruction manual. Thank you for reading. If you have any question, please call us or leave a message on our company's website. We will respond you quickly with sincere service. Wish you a happy application!